

BCTR 2000 Series Wireless Transmitter\Transceiver**HIGHLIGHTS**

- Can act as a transmitter or repeater for Sapling Wireless systems
- TCP/IP internet connection
- Frequency tuning circuit to allow for time correction with changes in temperature
- Field-enabled Daylight Savings Time (when used as a primary master clock)
- Can act as an interface between existing systems to Sapling Wireless systems
- Can be used as a wired or wireless transceiver/repeater to Sapling Wireless systems
- Transmits the Sapling wireless signal to the BCAL and BCBL series wireless clocks
- 915-928 MHz frequency-hopping technology
- Microprocessor based
- Can transmit up to 1000 meters in open space
- Loaded, half wave antenna
- Input sensitivity: -103 dbm
- Power output: 27 dbm
- Programmable relay output
- Input for interfacing with other systems such as 59 minute correction, 58 minute correction, National Time and Rauland, Dukane, etc.
- LED display for a clear, accurate readout
- Self testing mode allows the user to test the real time clock, output relay, LED segments, and inputs
- Simple interactive menu system
- Slim design makes the Wireless Transceiver versatile for mounting
- Easy programming via two (2) switches
- Analog and digital wireless clocks can be mixed on the same system
- RS485 input and output
- LEDs for indication of transmission or receipt of RS485 signal
- 85-265 VAC input voltage making it accessible for American or European use
- Transmits wireless signal every minute
- Compact design makes the BCTR 2000 ideal for mounting in hallways
- FCC Approved, part 15 Section 15,247
- Made in the U.S.A.

DESCRIPTION

Sapling's innovative multi-functional transceiver is designed to wirelessly transmit data to the BCAL analog wireless clock and the BCBL wireless clock while receiving the time signal from an atomic clock web site via the Internet. Upon connection of the LAN cable, the atomic clock web site will start up automatically. The transceiver is also capable of receiving signals from all of the Sapling Master Clocks, as well as 59 minute correction, 58 minute correction, National Time and Rauland and Dukane. By utilizing one of the above mentioned inputs, the transceiver can transform a wired system to a wireless system. The transceiver comes equipped with a programmable auxiliary relay that can be programmed anywhere from 1- 99 seconds. By utilizing this relay, interfacing with other systems via once a day closure and interfacing with intercom systems becomes effortless. In addition to the aforementioned features, the transceiver can act as a repeater while receiving a signal wired or wirelessly from the main transmitter. The transceiver has a temperature controlled time base allowing calibration of the time base during variants in temperature. The BCTR 2000 is very user friendly and easy to operate via two (2) switches. The transceiver has diagnostic capabilities which makes it easy to maintain. The BCTR 2000 can also interface with the BCAM Series via the converter box, as well as the BCBD 1000 digital clock and the BCRM analog clock via RS485 communication. The transceiver works on 915 - 928 MHz frequency-hopping technology that allows for a better and clearer signal even if there is interference in one of the frequencies. The BCTR 2000 is powered using 110 volts / 60 Hz and 220 volts/50 Hz. The transceiver is FCC approved, part 15 Section 15,247.

BCTR 2000 Series Wireless Transmitter\Transceiver

SPECIFICATIONS

• Time Base:	Quartz crystal
• Frequency Aging:	5 ppm/year
• Frequency Stability:	5 ppm/year
• Input voltage:	85 - 265 VAC, 50/60 Hz
• Power Input:	35 watts
• Input frequency:	47 - 440 Hz
• Input sensitivity:	-103 dbm
• RF signal output:	27 dbm
• Display:	.56" seven segment LEDs
• Display format:	12 or 24 hoursl
• Battery backup:	Ten (10) years
• Temperature range:	
• Operating:	0°C - 50°C
• Storage:	-15°C - 70°C
• Signal input:	RS485, 59 minute, 58 minute, National Time and Rauland sync wire, once a day
• Signal output:	RS485, Sapling Wireless Com- munication
• Internet connection:	TCP/IP LAN port
• Output relay closures:	
• Duration:	1 - 99 seconds
• Programmable time:	HH:MM:SS format
• Contact rating:	8 amps, 0 - 220 Volts
• Transmission frequency:	915 - 928 MHz
• Calendar:	Built-in calendar with leap years
• Programmable operation:	Via two (2) switches
• Mounting:	Wall mount
• Color:	Gray
• Housing:	Smooth surface metal enclosure
• Enclosure size: (LxWxH)	2.75" x 6.75" x 7.5"
• Shipping weight:	3.5 lbs.
• Shipping box dimensions:	15.25" x 10.13" x 5"
• Antenna length:	7"
• Compliance:	FCC Compliant. FCC part 15 Section 15.247

ARCHITECTURAL AND ENGINEERING SPECIFICATIONS

The Master Clock / Transmitter shall be the Sapling BCTR 2000 Transceiver. The transmitter shall be capable of transmitting data to the BCAL wireless analog clock and the BCBL wireless digital clock. The transmitter shall be capable of receiving a signal from an atomic clock web site via the Internet. The transmitter will be capable of receiving signals from all Sapling Master Clocks via RS485, as well as 59 minute correction, 58 minute correction, National Time and Rauland, and Dukane. The transmitter shall have the capability of transferring a wired system into a wireless system. The transmitter shall have a programmable auxiliary relay and shall be programmed anywhere from 1—99 seconds. Upon utilization of the relay, the transmitter will be capable of interfacing with a once a day closure or interfacing with intercom systems. The transmitter shall be capable of acting as a repeater while receiving a signal wired or wirelessly from the main transmitter. The time base shall be temperature controlled allowing calibration of the time base during temperature changes. The transmitter will have two (2) switches for operation of the menu system. The transmitter shall be capable of interfacing with the BCAM Series analog clock via the Converter Box, and the BCRM Series analog clock and BCBD 1000 digital clock via RS485. The transmitter shall utilize 915–928 MHz frequency-hopping technology. The transmitter shall be FCC compliant, part 15 Section 15.247.

MECHANICAL DRAWING

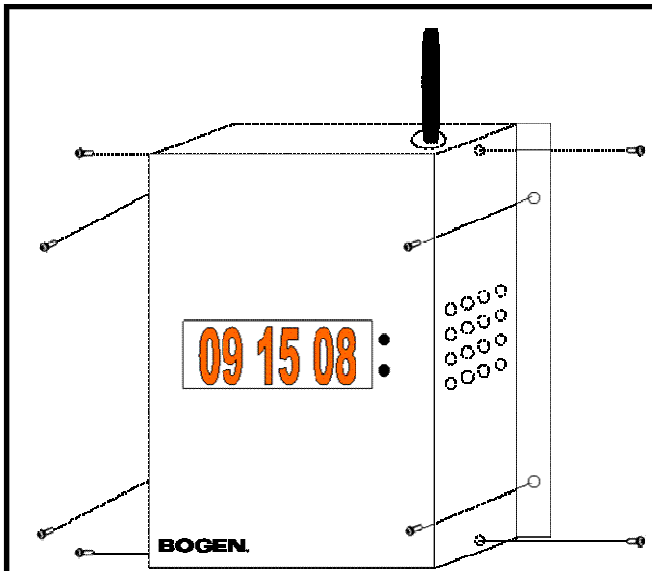

ORDERING INFORMATION

TRANSCEIVER :

BCTR-200-056-1