

BCBL 1000 Series Wireless 2.5" and 4" Digital Clock**HIGHLIGHTS**

- Receives and transmits the signal once a minute
- External antenna
- Each clock acts as a repeater and transmitter
- 915–928MHz frequency-hopping technology
- Immediate correction for time change
- Microprocessor based clock
- Clocks will not deviate from each other
- Available in 2.5" display and 4.0" display
- 12 or 24 hour format
- Two (2) levels of adjustable brightness
- Loss of communication alert
- Bright LED display
- Anti-glare red or blue bezel
- No battery backup required
- Dynamic range for input voltages
 - 12 - 30 VDC (24 Volt model)
 - 12 - 30 VAC (24 Volt model)
 - 78 - 130 VAC(110 Volt model)
- Compatible with the BCAL series analog clocks
- Designed to work in conjunction with the Bogen Transceiver
- Plug in Molex connectors
- Available in red or blue displays
- FCC Compliant, FCC part 15 Section 15,247
- Made in the U.S.A.

DESCRIPTION

Bogen's new BCBL 1000 Series wireless digital clocks are available with either 2.5" high characters or 4.0" high characters in a four (4) digit display. The BCBL 1000 Series digital clocks are reliable slave clocks designed to work in conjunction with the Bogen Transceiver (part number BCTR-200-056-1). The innovative 915–928 MHz frequency-hopping technology allows for a better and clearer signal even if there is interference in one of the frequencies. Not only can each clock receive the wireless signal, it also transmits the signal which eliminates the need for many repeaters. The BCBL 1000 Series clocks are designed to automatically work together without causing interference with each other. In fact, a large number of clocks in a specific area would increase the quality of the signal to each unit. The BCBL 1000 Series is based on our high efficiency, bright LED display. The clocks implement immediate correction upon receipt of the digital signal. The BCBL 1000 features many options including 12 or 24 hour format, as well as two (2) brightness settings. The BCBL 1000 Series digital clocks can be mounted in a surface or double mount housing. The BCBL 1000 Series clock also features LEDs on the board to show if the clock is receiving data, making it easier to maintain and install. The unique, specially molded anti-glare bezel gives a smooth, clean look with no visible external screws. The BCBL Series wireless digital clock is FCC compliant, part 15, section 15,247.

BCBL 1000 Series Wireless 2.5" and 4" Digital Clock

SPECIFICATIONS

- Display size: 2.5" and 4.0" characters
- Display color: Vibrant red or blue
- Visibility: 100 feet — 2.5" Clock
250 feet — 4.0" Clock
- Bezel color: Anti-glare red or blue
- Bezel size: (LxW) 4.69" x 10.31" — 2.5" Clock
6.75" x 13.31" — 4.0" Clock
- Operating frequency: 915 - 928 MHz frequency-hopping technology
- Temperature range:
Operating: 0°C - 45°C
Storage: -15° - 75°C
- Input sensitivity: -103 dbm
- Power output: 8 dbm
- Input voltage for 2.5" clock; 12 - 30 VDC (24 Volt)
12 - 30 VAC (24 Volt)
78 - 130 VAC (110 Volt)
- Input voltage for 4.0" clock: 16 - 28 VDC (24 Volt)
14 - 28 VAC (24 Volt)
85 - 135 VAC (110 Volt)
- Average current consumption: (Max Brightness)
2.5" Clock
85 mA @ 24 VAC
30 mA @ 110 VAC
4.0" Clock
190 mA @ 24 VAC
45 mA @ 110 VAC
- Signal input: Bogen Wireless Communication
- Signal output: Bogen Wireless Communication
- Display format: 12 or 24 hour mode
- Brightness: 2 levels, adjustable
- Mounting: Surface and double mount
- Shipping weight: 2 lbs. — 2.5" clock
3.5 lbs. — 4.0" clock
- Shipping box dimensions:
2.5" Clock: (LxWxD) 7.5" x 11.375" x 4.25"
4.0" Clock: (LxWxD) 9.75" x 14.25" x 4.25"
- Power kit includes: 1 - 5 pin power harness
1 - 4 pin RS485 harness
4 - 6-32 x 1/2 machine screw
1 - 6-32 hex nut
1 - tooth lock washer
1 - grounding wire, loop end
- Compliance: UL, cUL, and FCC approved, FCC part 15 Section 15.247

ARCHITECTURAL AND ENGINEERING SPECIFICATIONS

The clock shall be a Bogen BCBL 1000 wireless digital clock and shall have either a full 2.5" or 4.0" high efficiency red or blue LED numeral display. The clock will operate as a wireless digital slave clock. The clock shall receive signals from other clocks in the surrounding area or from the transceiver. The clock shall receive and transmit with 915–928MHz frequency–hopping technology. The clocks will be capable of transmitting and receiving the time without interfering with each other. The clock shall have data LEDs on the board to display the receiving of data. It shall have a 12 or 24 hour display format. The clock will have two (2) levels of adjustable brightness and will feature immediate correction for time changes. The digital clock shall be capable of being installed either surface or double mount. When the input is lost, the colon on the display of the clock shall flash. The clock shall have an anti–glare red or blue bezel with a smooth surface. No external screws shall be visible on the bezel or clock housing. The clock shall be FCC compliant, part 15 Section 15.247.

MECHANICAL DRAWING

Surface Mount

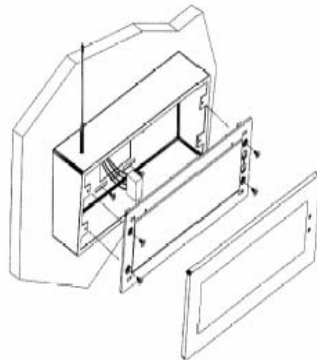

Double Mount

